

Grundkorpus
1x VFWG18/*

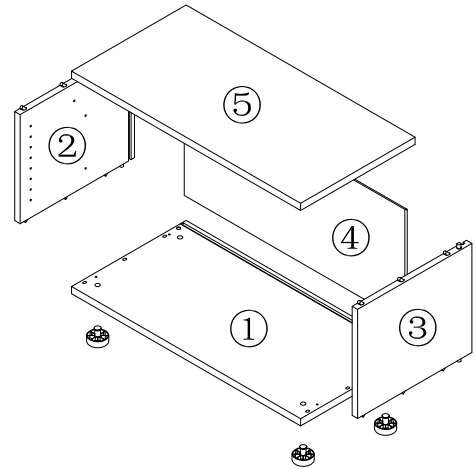

*assembled with /
montiert mit: click furniture technology

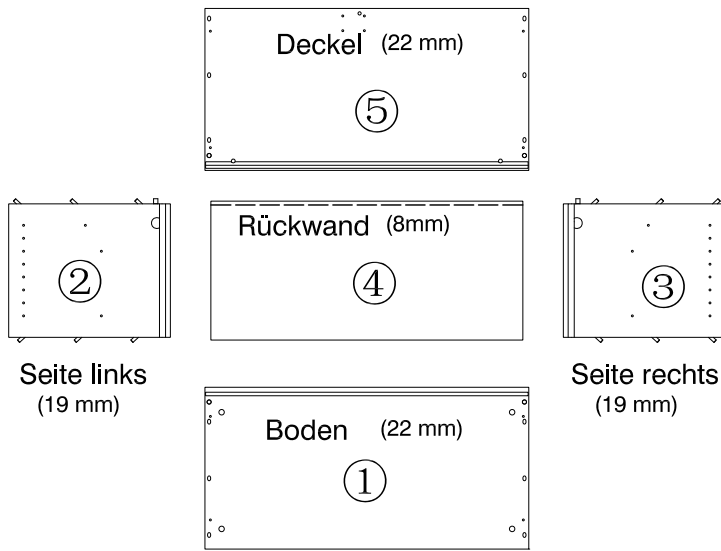

<p>4 x (A) 55mm</p> <p>500568</p>	<p>4 x (B)</p> <p>500547(S)</p>	<p>4 x (C)</p> <p>604898(W) 604899(G)</p>	<p>4 x (D) RW-lock</p> <p>604464</p>	<p>2 x (E) Demontage Pin</p> <p>604465</p>	<p>1 x (F) + 1 x (G)</p> <p>M4 x 15mm 500273</p> <p>M4 x 35mm 500275</p>	<p>1 x (H)</p> <p>500316</p>
---------------------------------------	---------------------------------	---	--	--	--	------------------------------

<p>Grundkorpus VFWG18/* LFWGK810/*</p> <p>MO_FWGK810.pdf</p>	<p>Aufsatzkorpus VFE18/* LFWAK810/*</p> <p>MO_FWGK810.pdf</p>	<p>Türen 1OH VFWT18/* LFWHT810/*</p> <p>MO_FWHT810.pdf</p>	<p>Türen 2OH VFWT28/* L9T2/*</p> <p>MO_9T2.pdf</p>	<p>Türen 3OH VFWT38/* L9T3/*</p> <p>MO_9T3.pdf</p>
<p>Metall-Rahmen VFWR18/* LFWMR810/*</p> <p>MO_FWGK810.pdf</p>	<p>Metall-Sockel VFWU08/* LFWMS810/*</p> <p>MO_FWGK810.pdf</p>	<p>Schubkästen VFWS28/* LFWSB810/*</p> <p>MO_FWS28.pdf</p>	<p>Akustik-Türe VFWA18/*/TO LFWAT810/*</p> <p>MO_FWA18.pdf</p>	<p>Akustik- RW VFWF18/* LFWFE810/*</p> <p>MO_FWA18.pdf</p>

Threespine® ist eine patentierte Technologie, die von Välinge Innovation AB erfunden wurde.
Die Wortmarke Threespine® und das Logo sind eingetragene Warenzeichen für die Klickmöbel-Technologie im Besitz von Välinge Innovation AB und werden unter Lizenz verwendet.
Threespine® is a patented technology invented by Välinge Innovation AB.
The Threespine® word mark and logo are registered trademarks for click furniture technology owned by Välinge Innovation AB and any use of such marks is under license.

1

4 x (A)

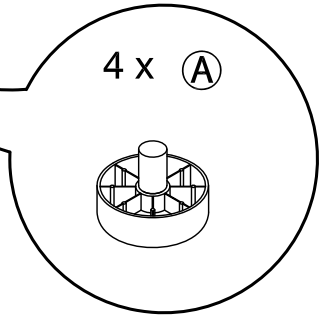
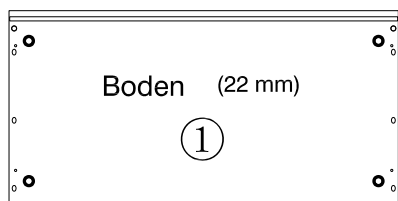
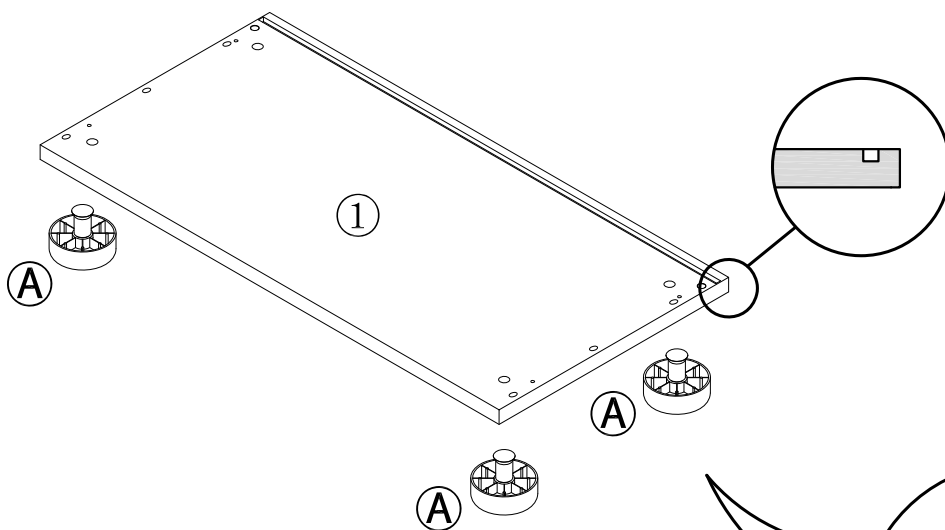
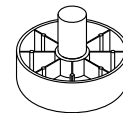

2

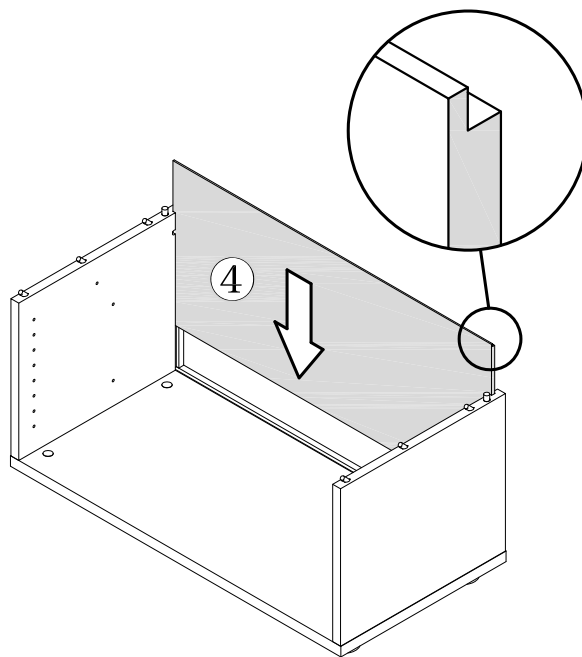
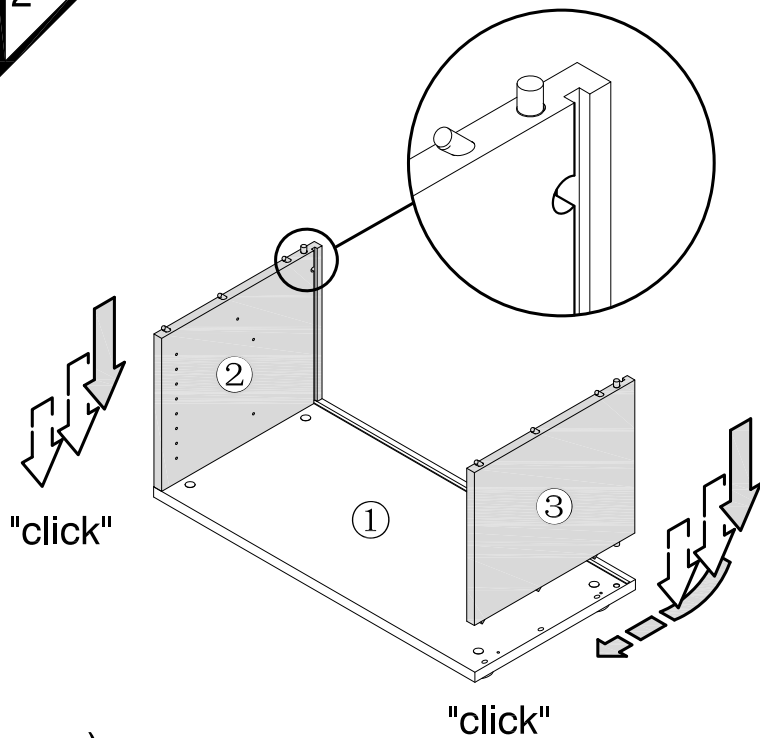

a)

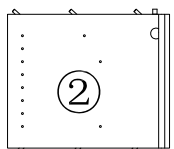

Seite links

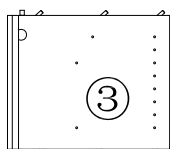

Seite rechts

b)

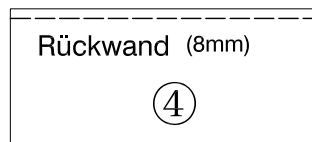

3

Endmontage: = 1 OH

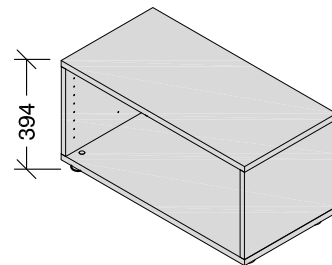

= 1 OH

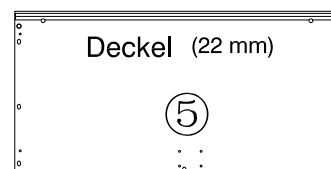
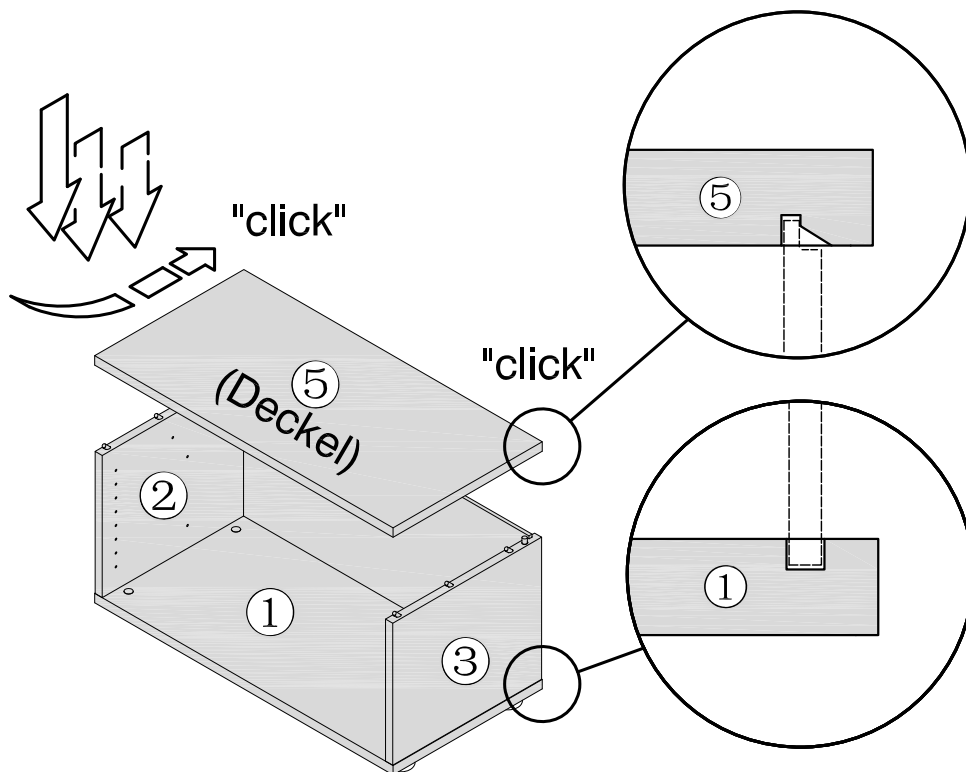

4

Endmontage: >1 OH

siehe ab Bild 7

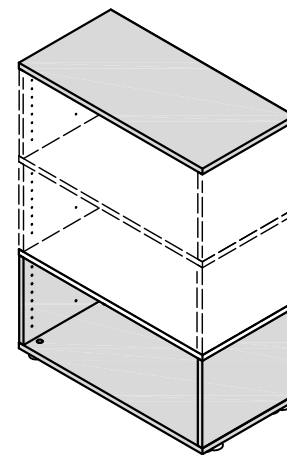

> 1 OH

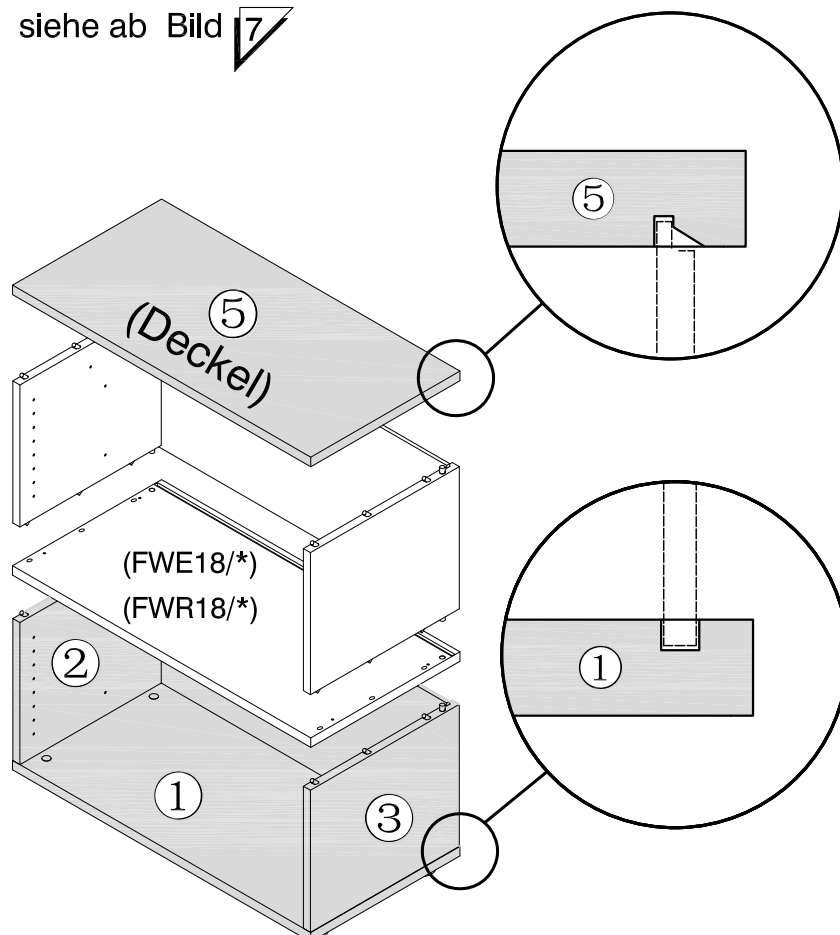

*assembled with /
montiert mit: click furniture technology

5

2 x (D)

RW-lock

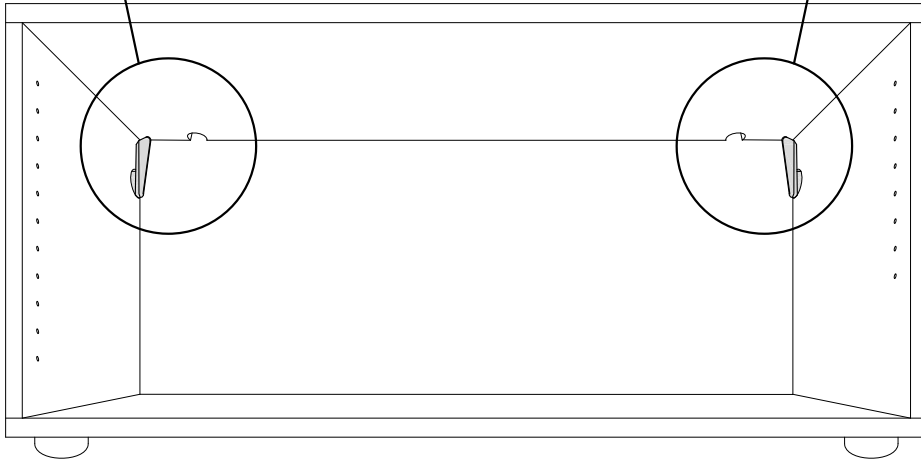
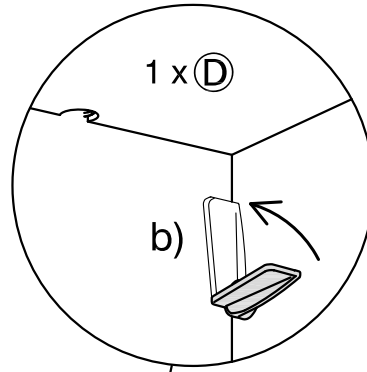
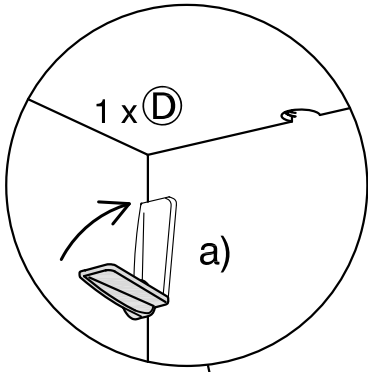
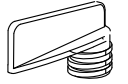

6

2 x (D)

RW-lock

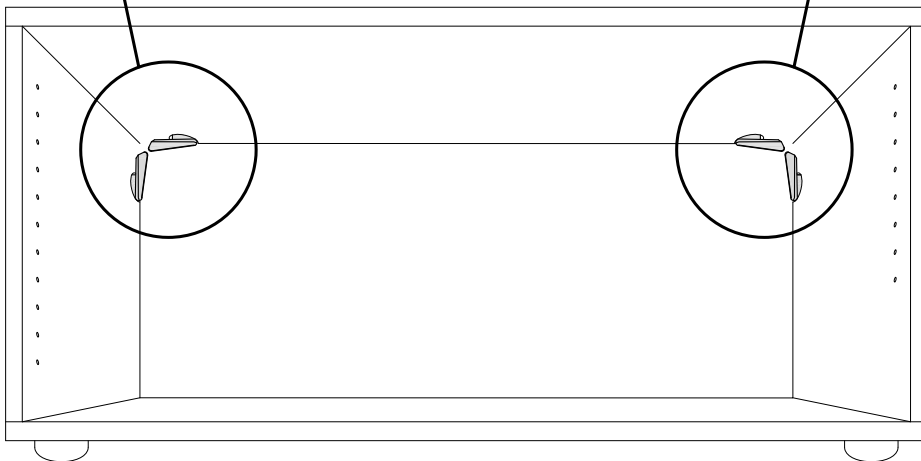
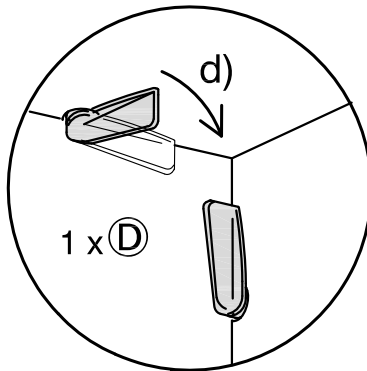
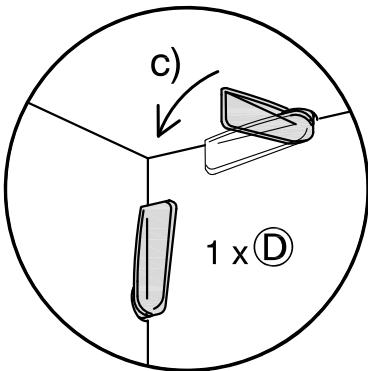
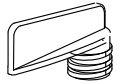

7

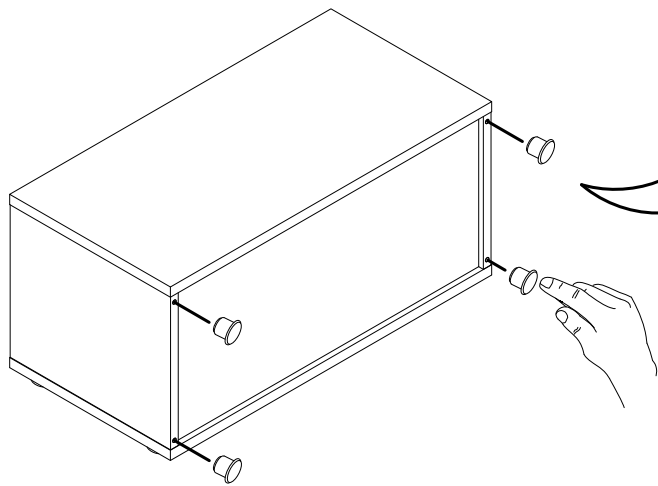

4 x C

4 x C



8 mm

4 x B



18 mm

4 x B

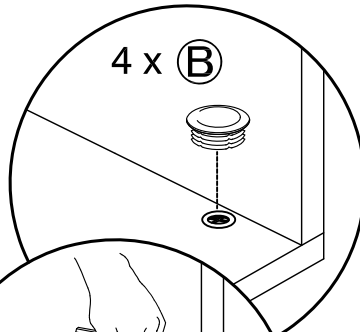

+/-

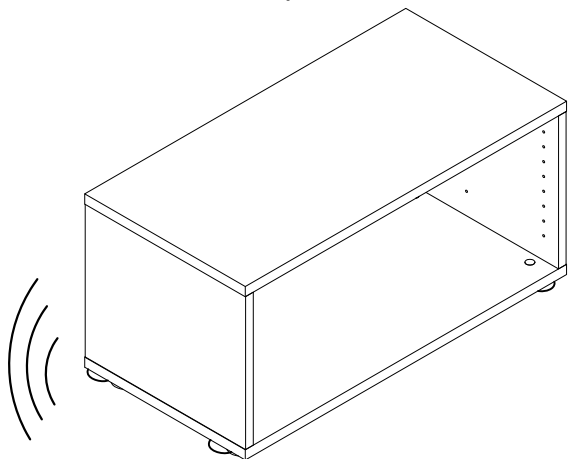
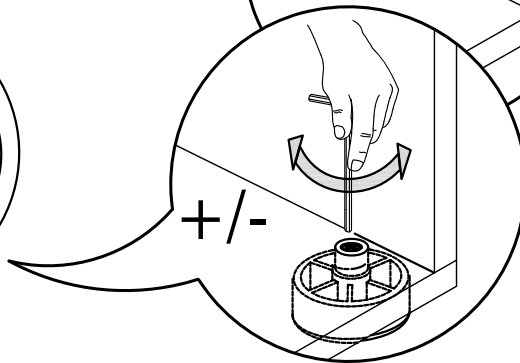

8

Demontage :



Video

2 x E

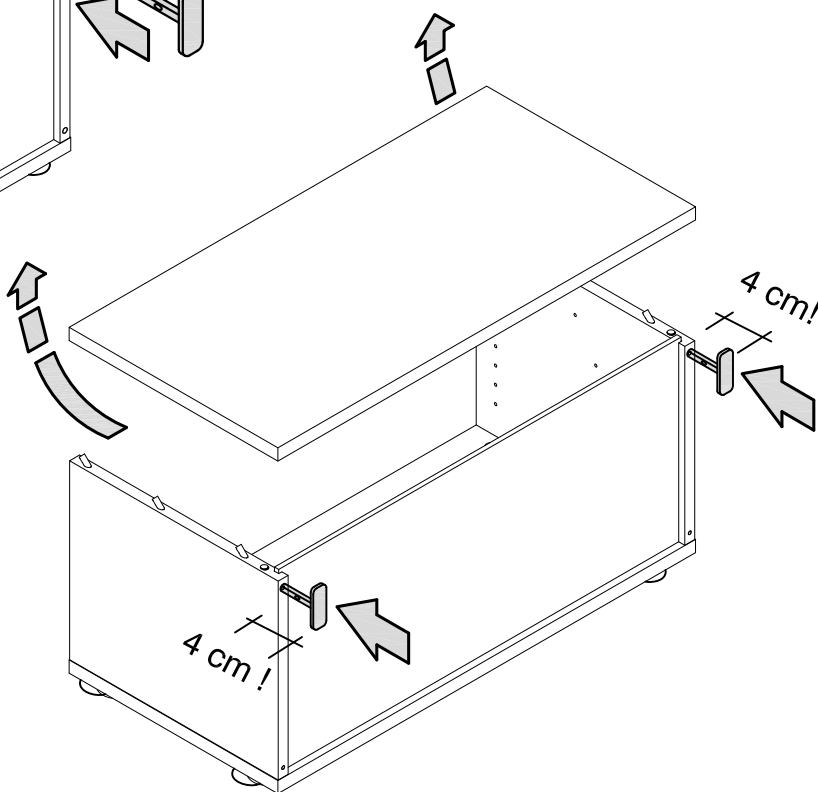
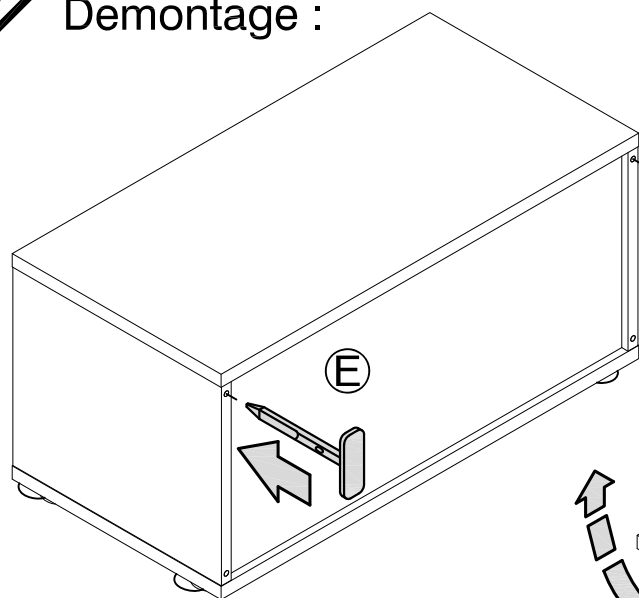
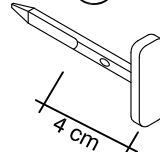

*assembled with /
montiert mit: click furniture technology

9

Erweiterung: Aufsatzkorpus

1x VFWE18/* (+ 1x VFWG18/*)

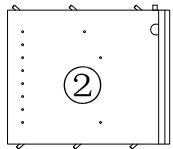
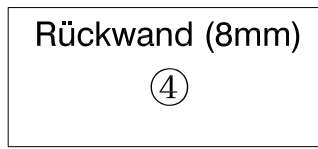
Seite links
(19 mm)

Rückwand (8mm)

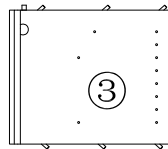
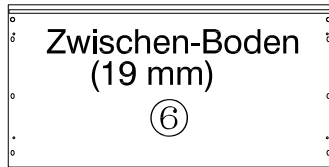
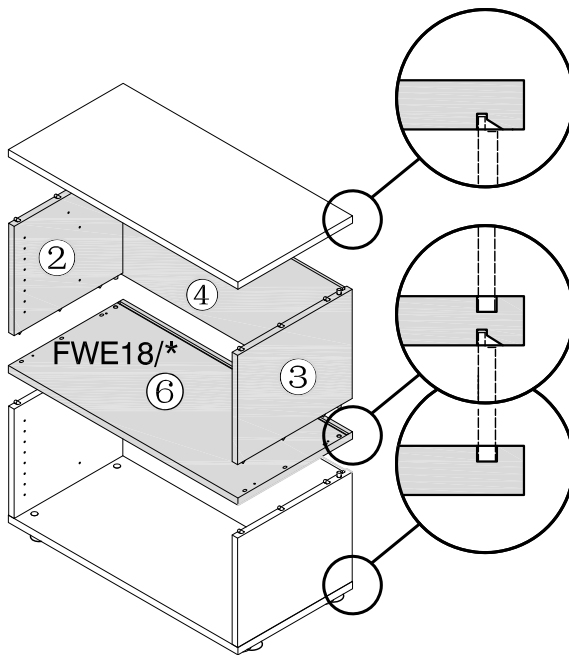
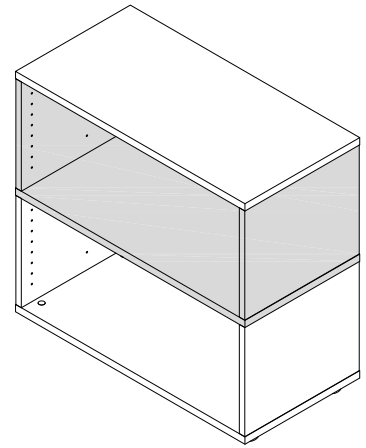
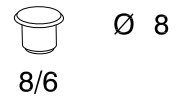
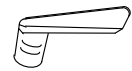
Seite rechts
(19 mm)Zwischen-Boden
(19 mm)4 x **C**604898(W)
604899(G)4 x **D**

RW-lock

604464

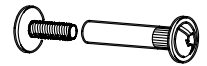
1 x **F** + 1 x **G**

500273 + 500275

10

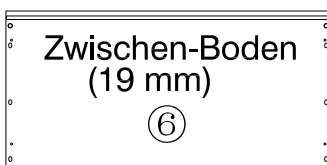
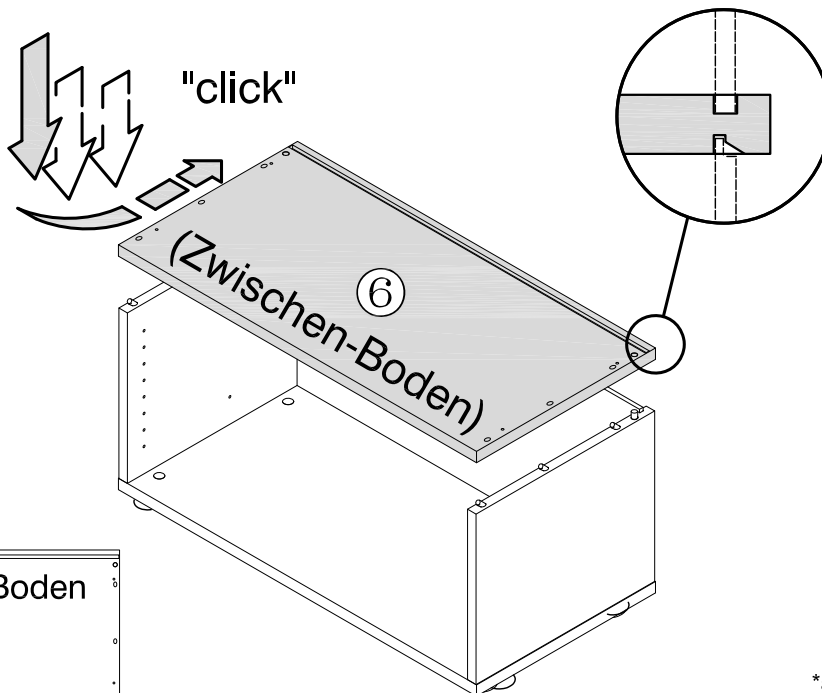
Zwischen-Boden
(19 mm)

⑥

Video



*assembled with /
montiert mit: click furniture technology

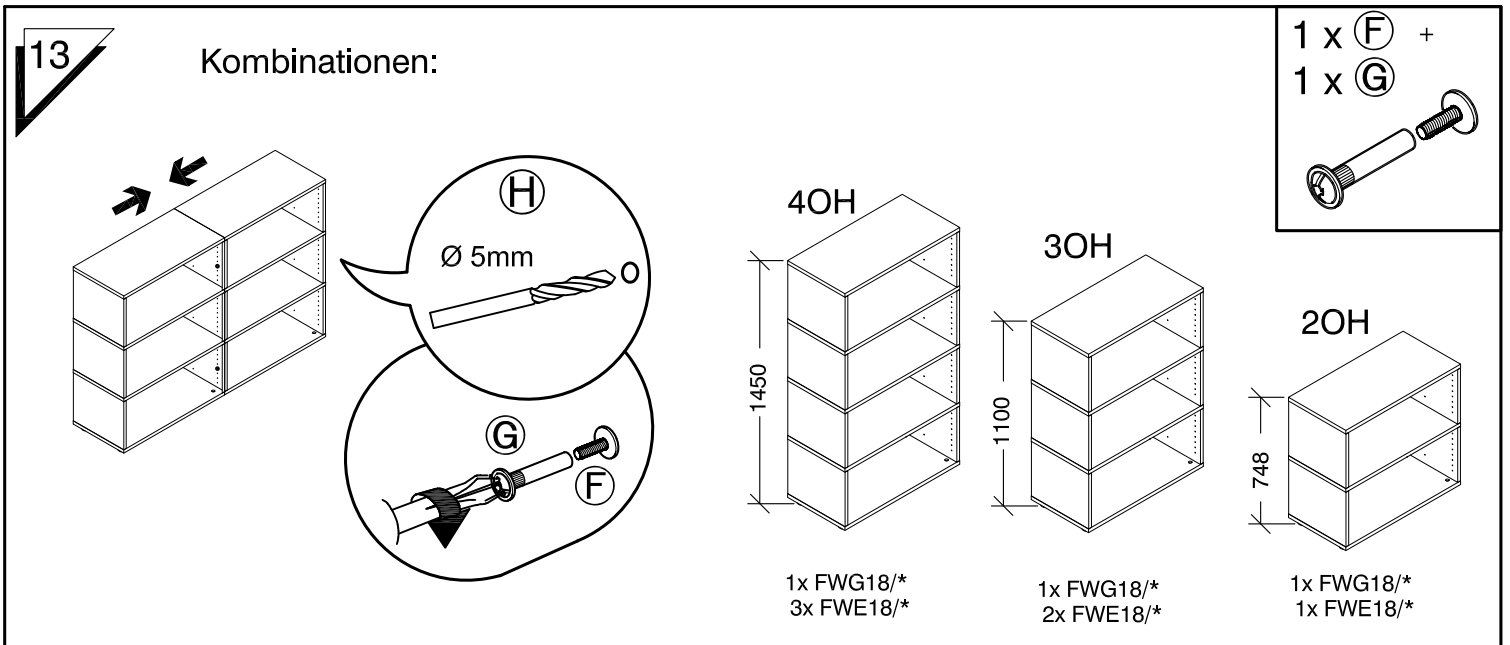
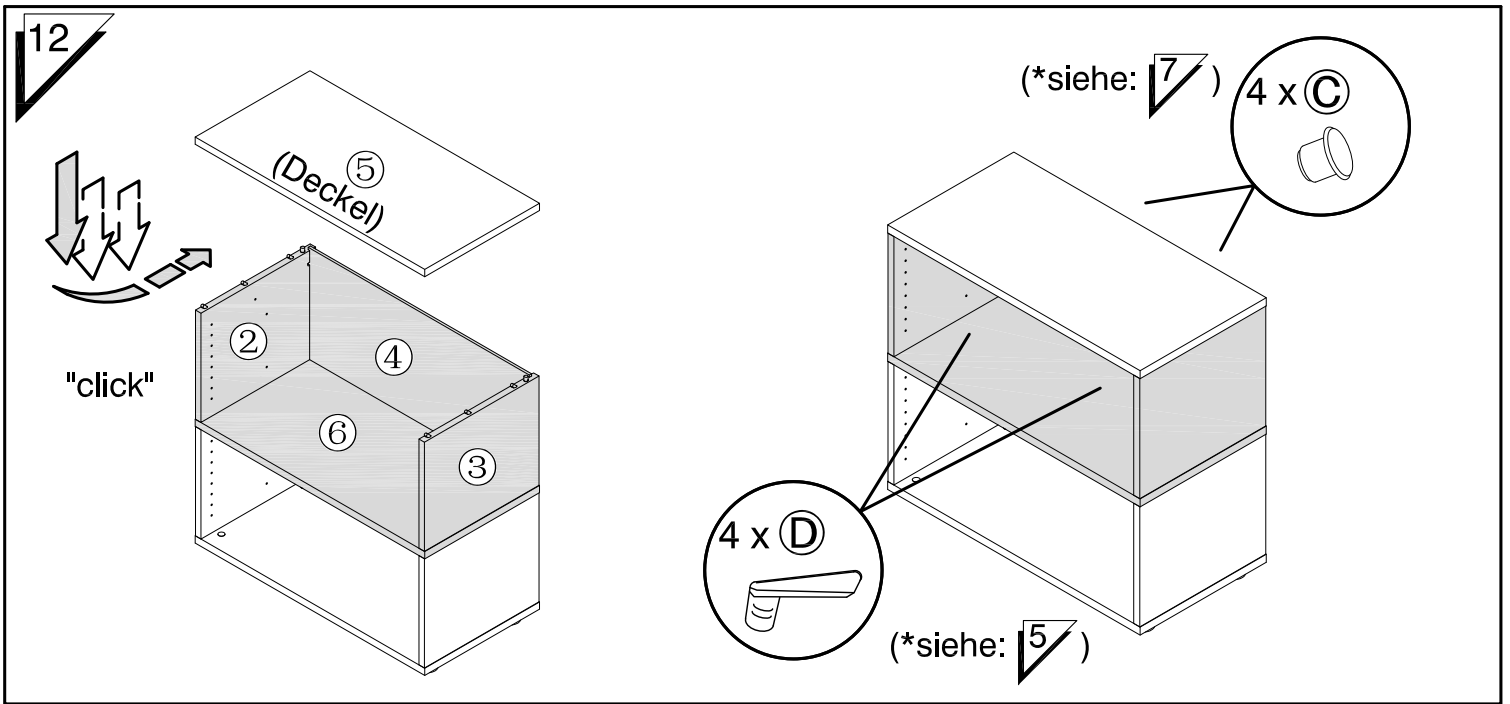
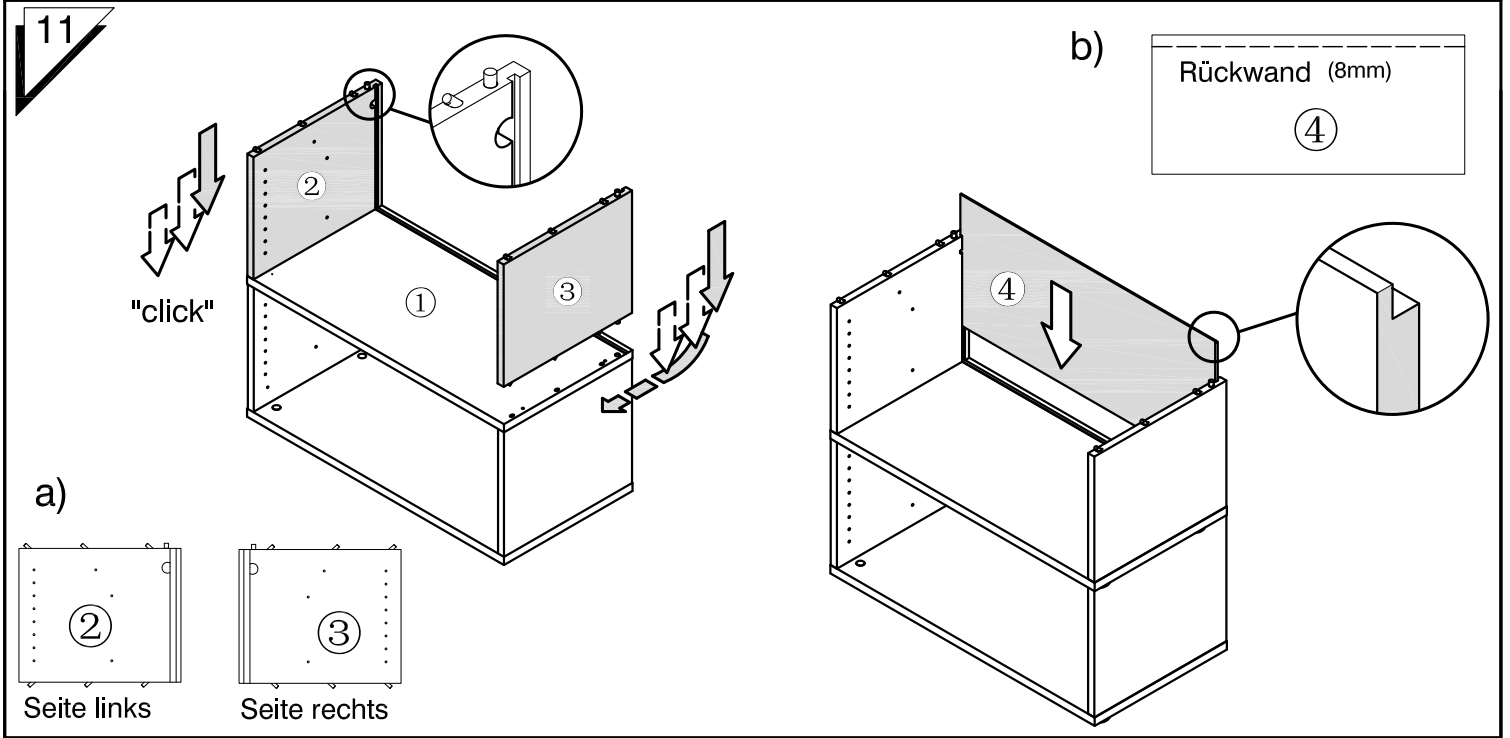

Erweiterung: Aufsatz Metall-Rahmen
 1x VFWR18/* (+ 1x VFWG18/*)

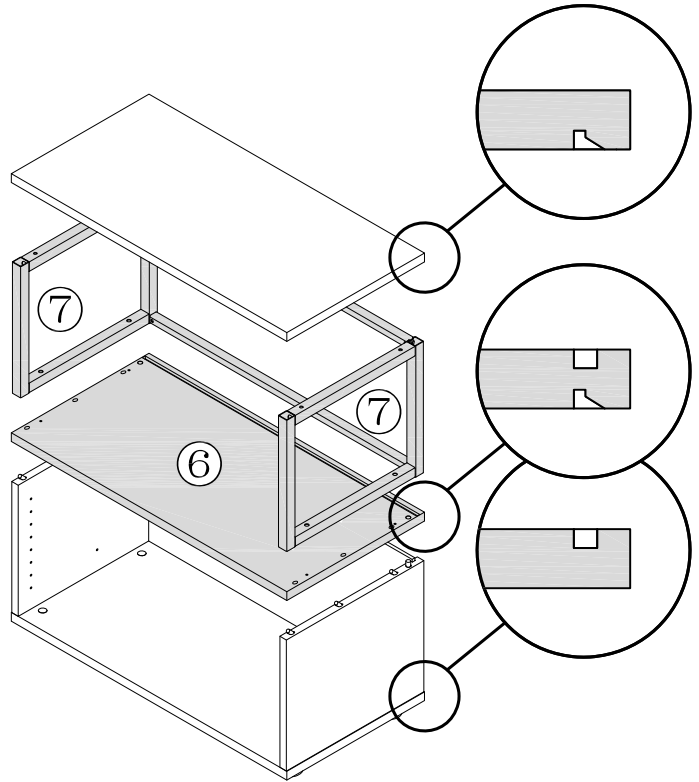
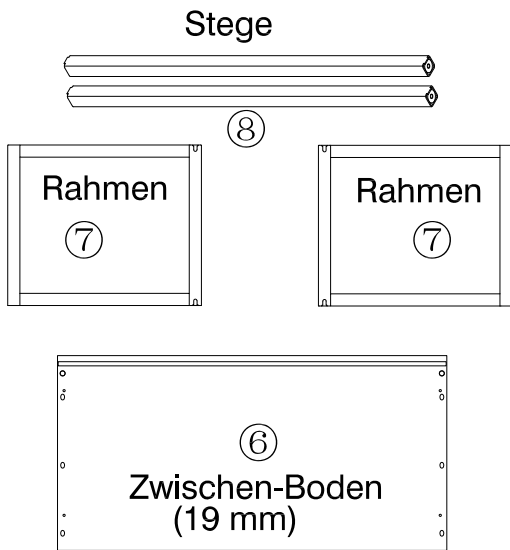

4 x (J)



M6 x 10

574845

8 x (K)

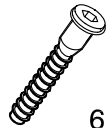

6,3 x 40

605445

8 x (M)

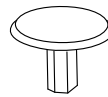

604897 (G)
508689 (W)

1 x (N)



500278

SW4

14

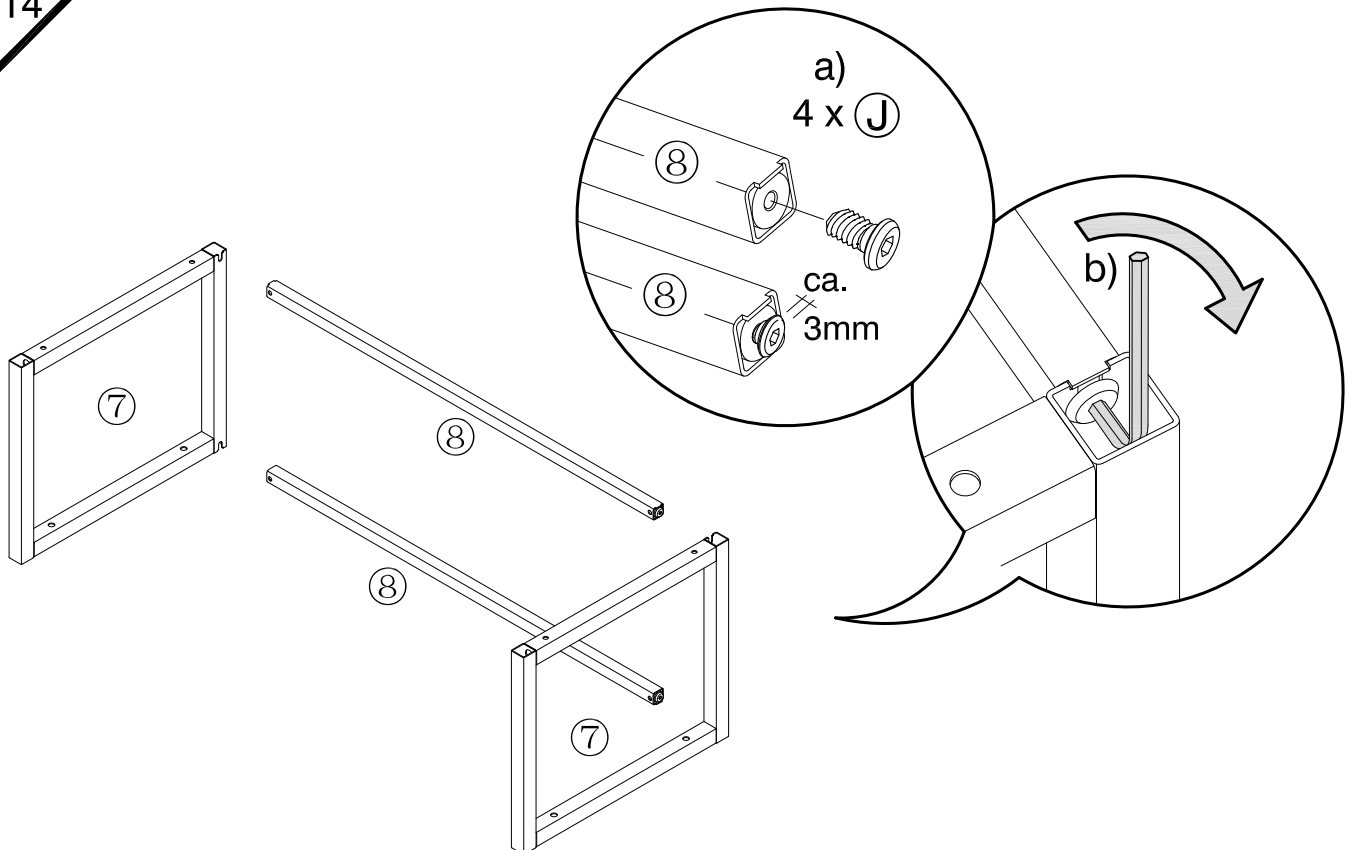

15

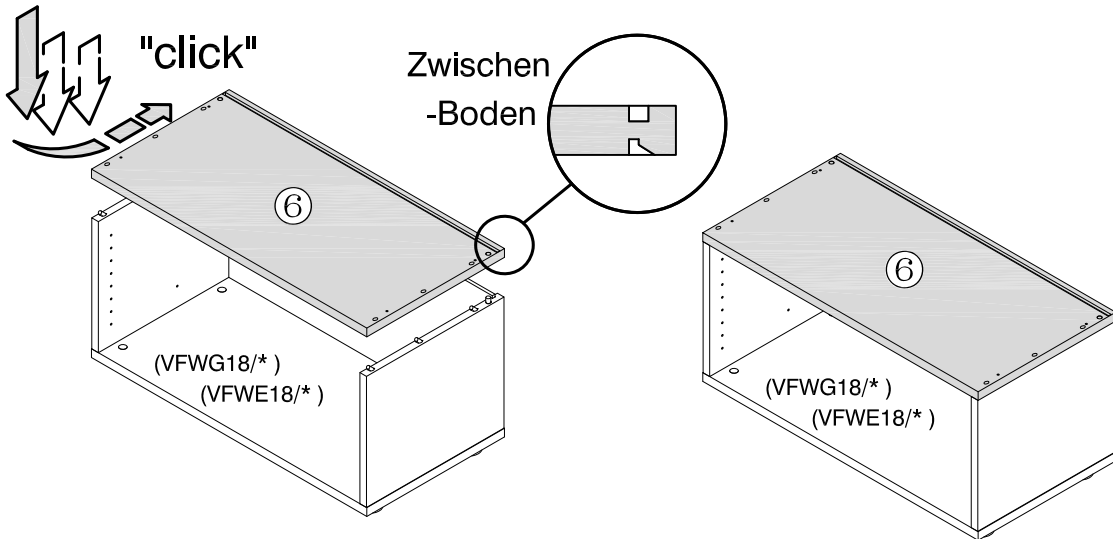

16

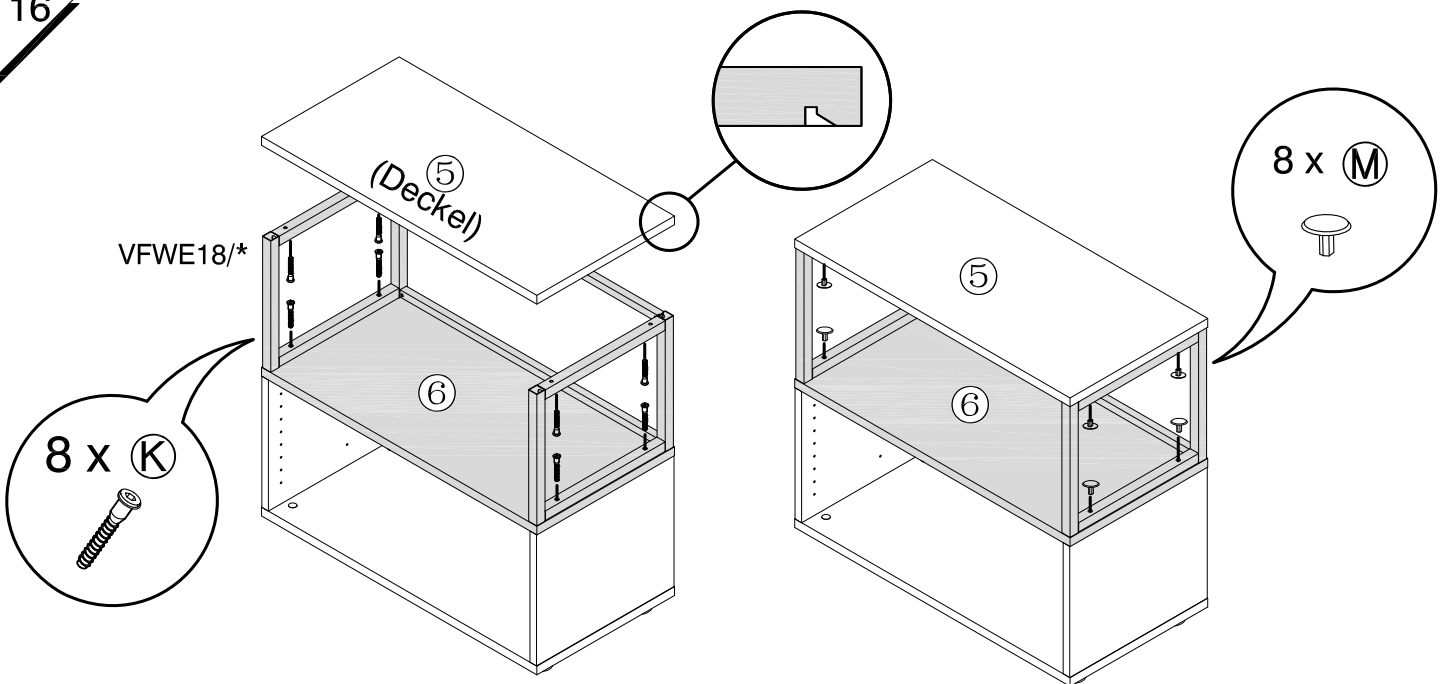

17

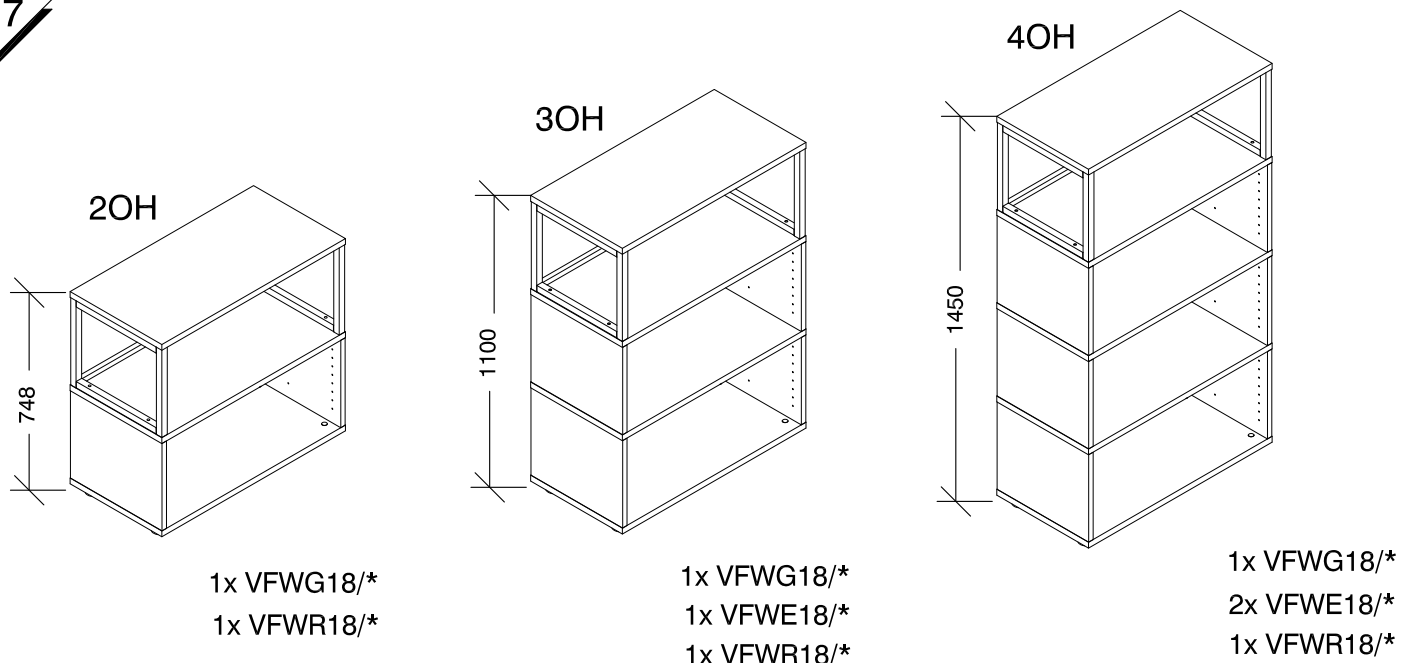

18

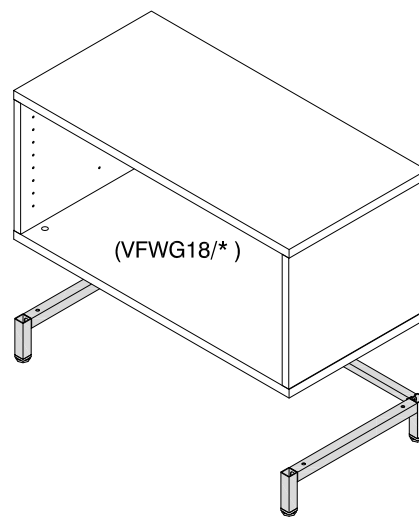
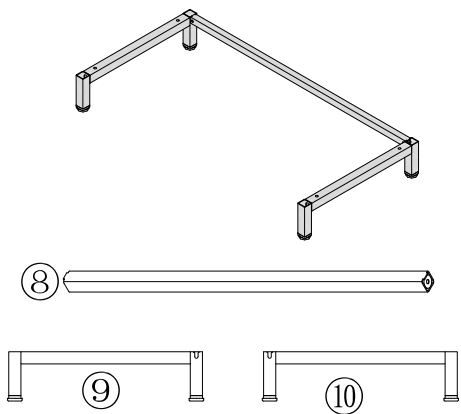
Metall-Sockel
VFWU08/*

2 x (J)



M6 x 10

574845

4 x (K)



6,3 x 40

605445

4 x (M)

604897 (G)
508689 (W)

1 x (N)



SW4

500278

19

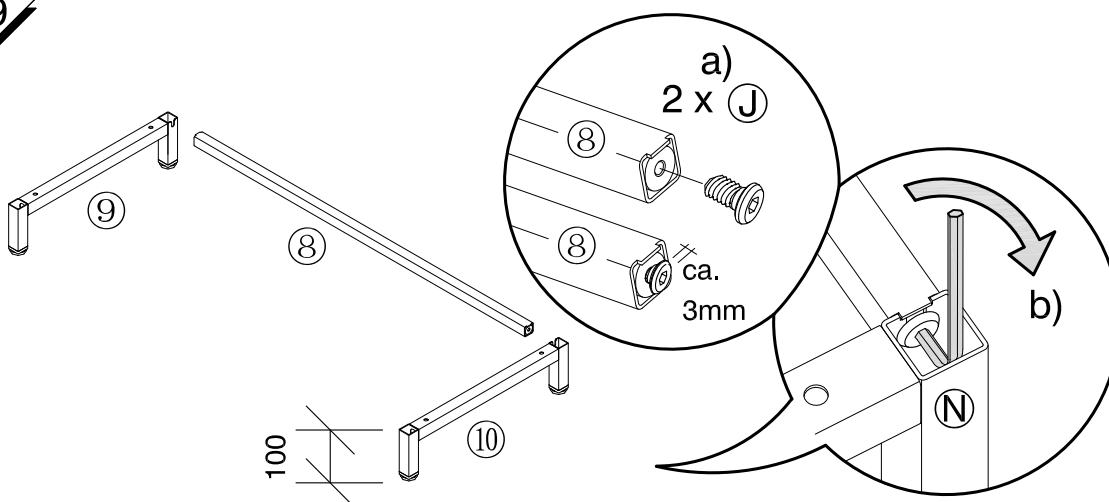

2 x (J)



M6 x 10

20

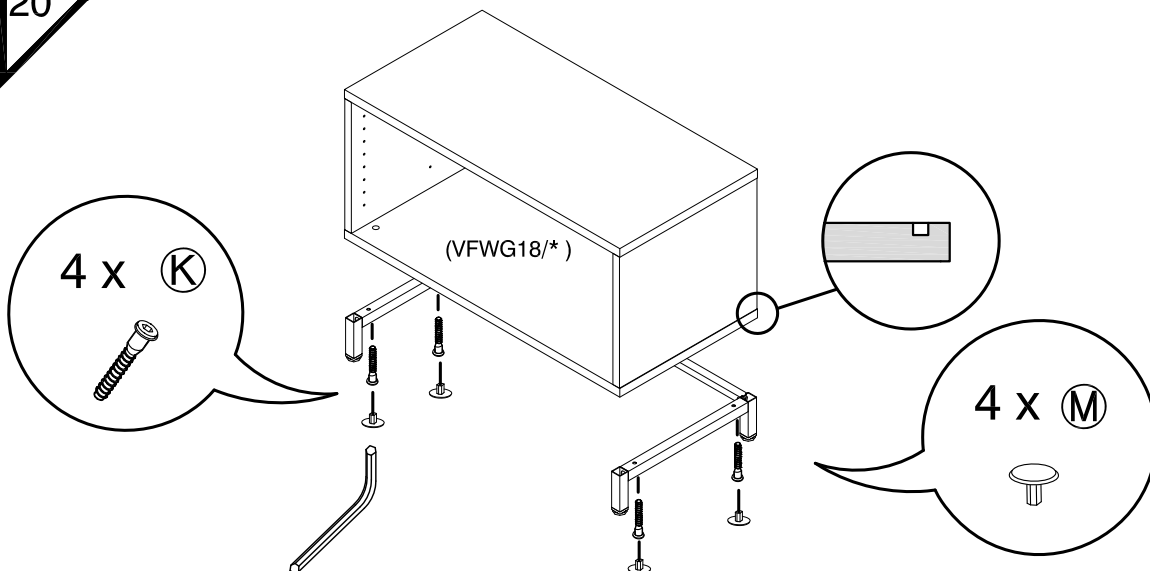

4 x (K)



4 x (K)



6,3 x 40

4 x (M)

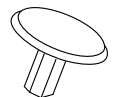

4 x (M)



Stellbeispiele:

(mit Sockel)

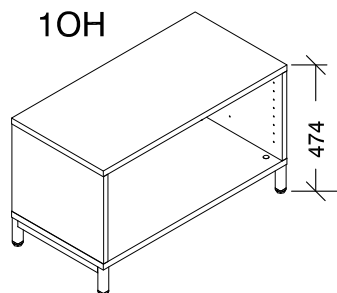

1x VFWG18/*
1x VFWU08/*

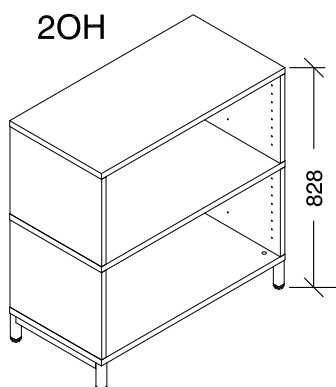

1x VFWG18/*
1x VFWE18/*
1x VFWU08/*

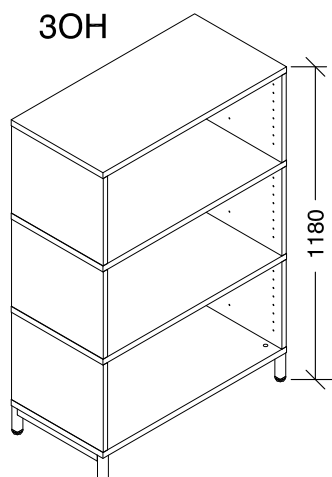

1x VFWG18/*
2x VFWE18/*
1x VFWU08/*

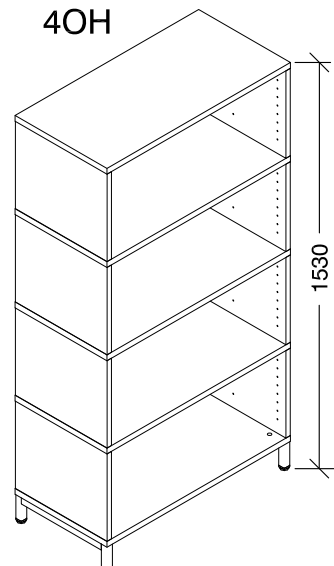

1x VFWG18/*
3x VFWE18/*
1x VFWU08/*

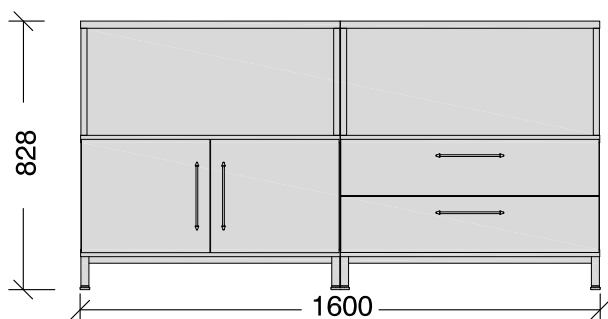

Stellbeispiel (A)

bestehend aus:
2x Grundkorpus VFWG18/*
2x Sockel VFWU08/*
2x Ergänzung VFWE18/*
1x Türenpaar VFWT18/*
1x Schubkastenpaar VFWS28/*

Stellbeispiel (B)

bestehend aus:
3x Grundkorpus VFWG18/*
3x Sockel VFWU08/*
6x Ergänzung VFWE18/*
1x Türenpaar 10H VFWT18/*
1x Schubkastenpaar VFWS28/*
2x Türenpaar 20H VFWT28/*

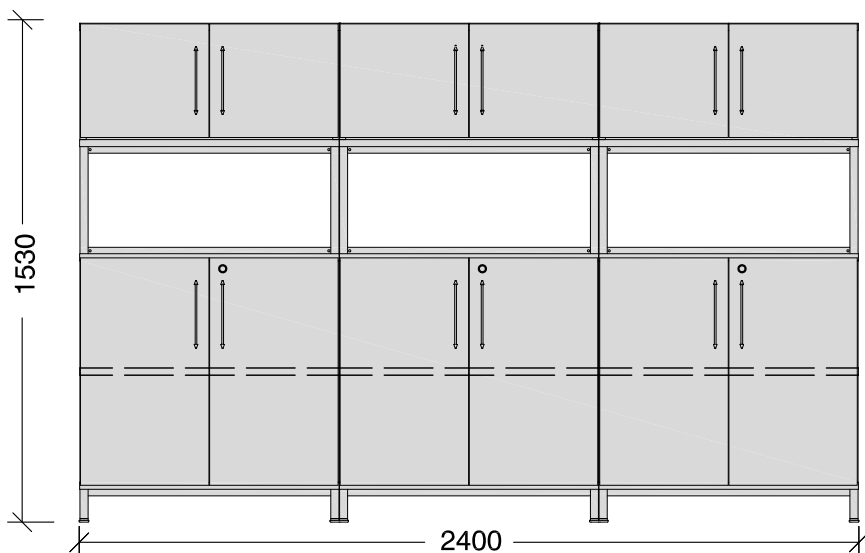
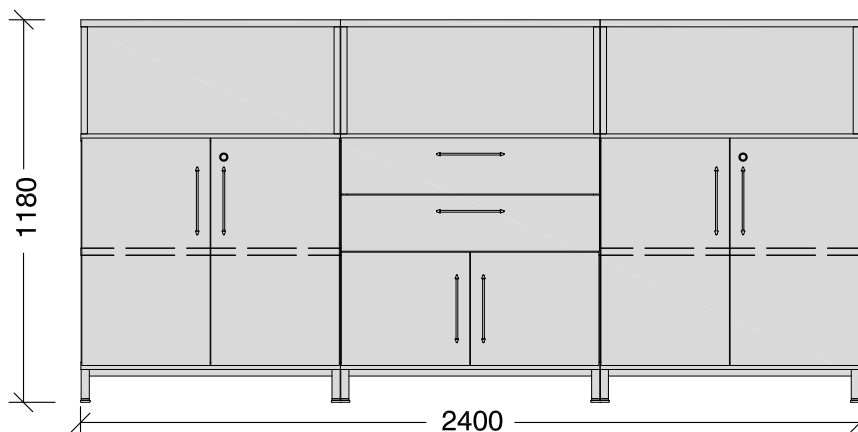

Stellbeispiel (C)

bestehend aus:
3x Grundkorpus VFWG18/*
3x Sockel VFWU08/*
6x Ergänzung VFWE18/*
3x Türenpaar 10H VFWT18/*
3x Türenpaar 20H VFWT28/*
3x Metallrahmen VFWR18/*



